

USER MANUAL



Table of content	
Content of the box	3
Intended use of the device.....	3
Description of the device	4
Connection of the device to the pipe	5
Configuration of the device before connecting to the pipe	10
Configuration of the device to work with RATMON system	11
RATMON system	12
Front panel	13
Description of LEDs	14
LED operation after starting of the device	15
Disposal	16

CONTENT OF THE BOX

- device RAT-2/RAT-Combo
- power transformer
- antenna



- ✓ Before using the device, read this user manual.
- ✓ Using this manual does not release you from the need to comply with other safety regulations.
- ✓ Any repairs or tampering with the device and its accessories may only be performed by the manufacturer's authorized service
- ✓ The device is covered by a 24 month warranty from the date of purchase.
- ✓ Due to the constant development of the device, the manufacturer has the right to update this manual without having to inform the users of the device.
- ✓ The current version of the manual is available at www.ratmon.com

INTENDED USE OF THE DEVICE

RAT-2 is the detector of leaks and faults in pre-insulated pipe network

Leak / Fault detection is done by measuring of 2 below parameters:

Rc - measurement of alarm loop continuity.

If **Rc** value exceeds the set limit of loop resistance it means loop's break or misconnection of alarm wires.

Riso - measurement of foam insulation resistance between metal pipe and alarm wire.

If the Riso value falls below the set insulation resistance limit it means the appearance of moisture / leakage.

RAT-2 can support 2 or 4 alarm loops.

DESCRIPTION OF THE DEVICE

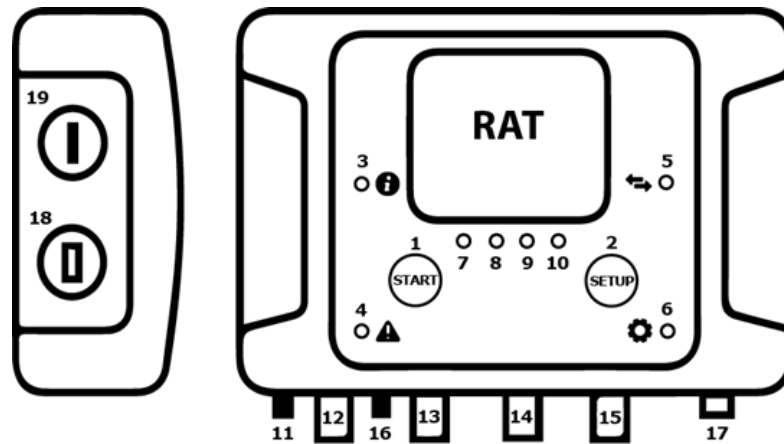

1. Button „Start”	11. Antenna socket
2. Button „Setup”	12. Connection channel 1 „CH1”
3. Status LED „i”	13. Connection channel 2 „CH2”
4. Alarm LED	14. Connection channel 3 „CH3”
5. Communication LED „Arrows”	15. Connection channel 4 „CH4”
6. Configuration LED	16. Connection „RELAY”
7. LED channel 1 „CH1”	17. Connection to power supply
8. LED channel 2 „CH2”	18. USB communication
9. LED channel 3 „CH3”	19. SIM card slot
10. LED channel 4 „CH4”	

CONNECTION OF DETECTOR TO THE PIPE

WARNING!

All connections of the detector to alarm wires and exchange of SIM card must be carried out with switched off power supply!!

CONNECTION OF RAT-2 DETECTOR TO ALARM WIRES WITHOUT CONNECTION BOXES.

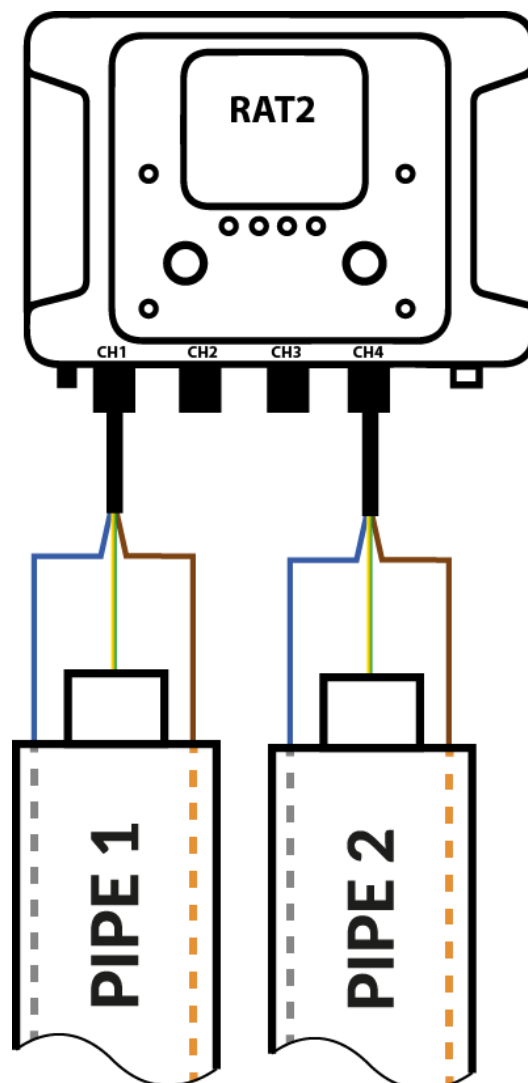

CONNECTION OF RAT-2 DETECTOR TO ALARM WIRES USING BOX-1

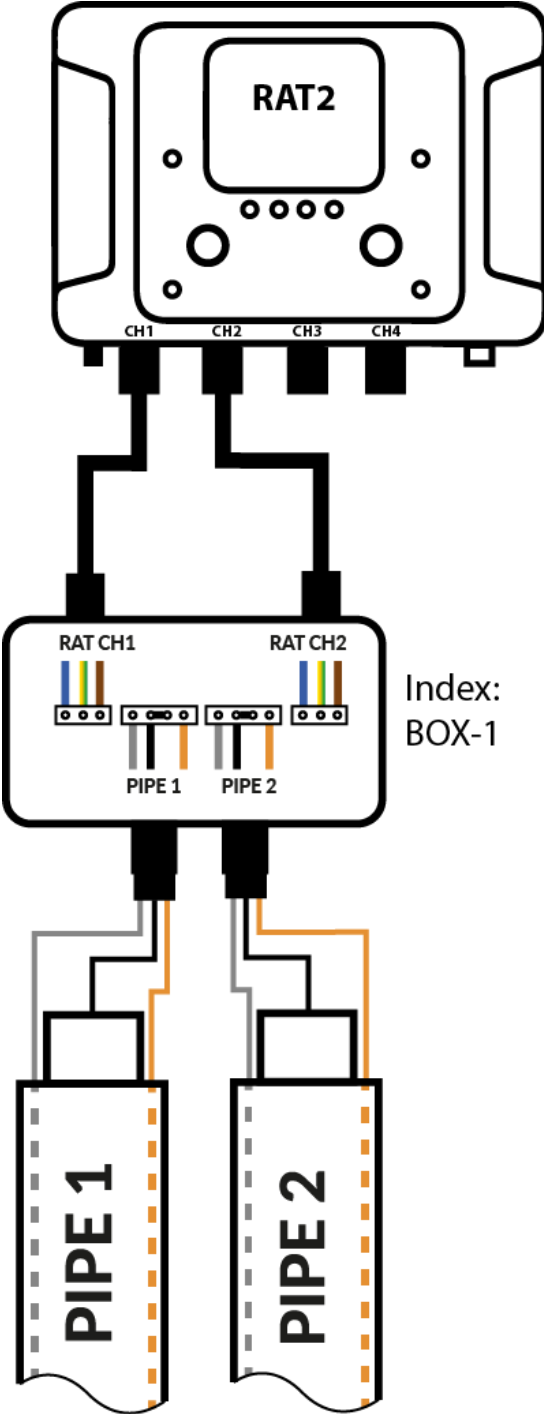

THE WAY OF CONNECTING RAT-2 DETECTOR TO THE ALARM WIRES USING BOX-1 INSTALLATION BOX IN RESISTANCE SYSTEM.

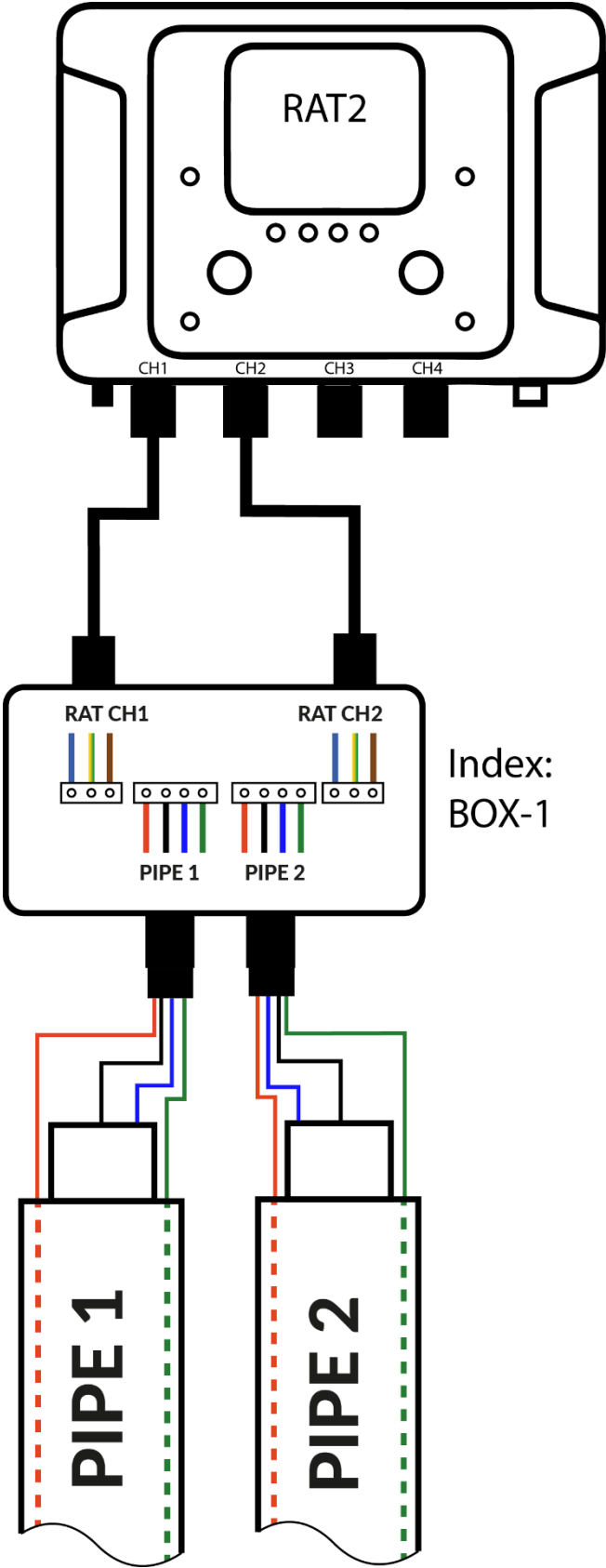

CONNECTION OF RAT-2 DETECTOR TO ALARM WIRES USING BOX-2

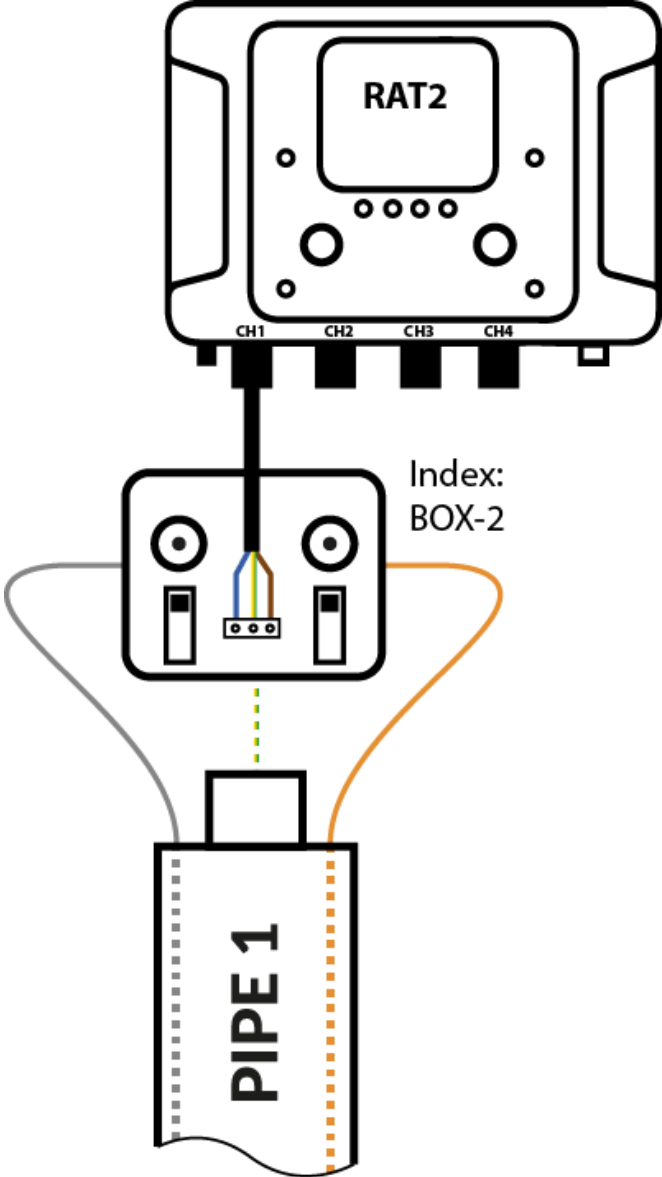

CONNECTION OF RATCOMBO TO ALARM WIRES WITHOUT CONNECTION BOXES.

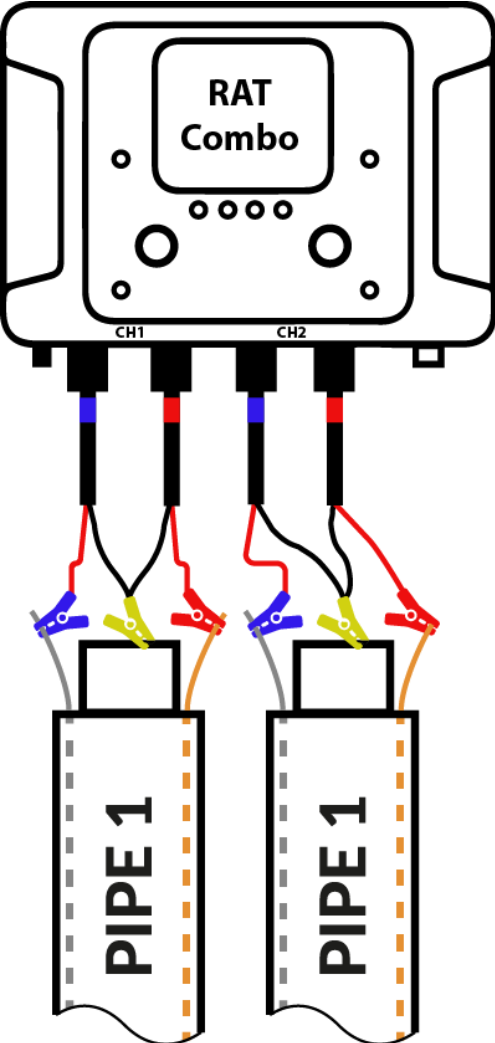

CONNECTION OF RATCOMBO TO ALARM WIRES USING BOX-3

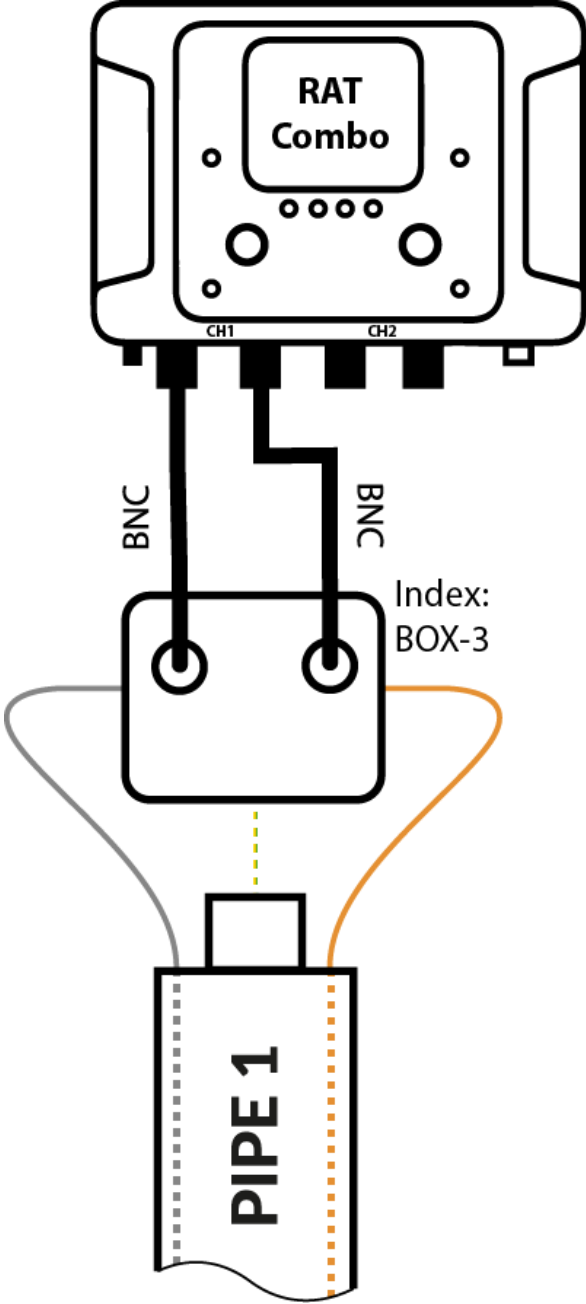

CONNECTION OF RELAY (option)

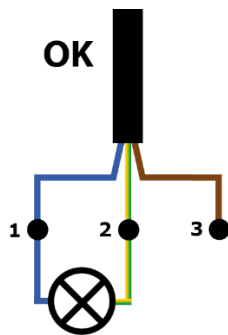

Normal operating condition – wires 1-2 shorted.

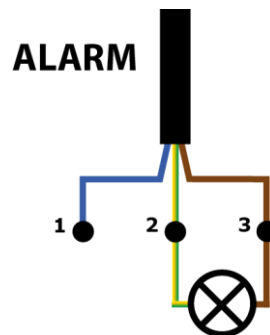

Alarm – wires 2-3 shorted.

CONFIGURATION OF THE DEVICE BEFORE CONNECTION TO THE PIPE

Each new device is set according to the configuration below:

Warning thresholds (LED CH flashes yellow):

Riso - foam insulation resistance: 1 [M Ω]

Alarm loop resistance Rc: 50 [Ω]

Alarm thresholds (LED CH flashes red):

Riso foam insulation resistance: 500 [k Ω]

Alarm loop resistance Rc: 100 [Ω]

Frequency of measurements: 1 per day

To change the settings, use the RAT Manager 2 software, available at www.ratmon.com (see RAT Manager 2 manual, settings).

If the device is equipped with a GSM module and is configured to work with the RATMON system, all parameters can be also changed by remote from RATMON system. Settings of operating parameters are read by remote from the system before each measurement and set to the next time interval.

CONFIGURATION OF DEVICE TO WORK WITH RATMON SYSTEM

1. Download and install on your tablet / computer with Windows 7/10 the current version of RATManager 2 (www.ratmon.com -> Download -> RATManager 2).
2. Connect the RAT device to the power supply.
3. Connect the RAT device to the computer using dedicated USB cable.
4. The connection of the device with the computer will be notified in the upper right corner of the RAT Manager software with the information: Connected to device (serial number).

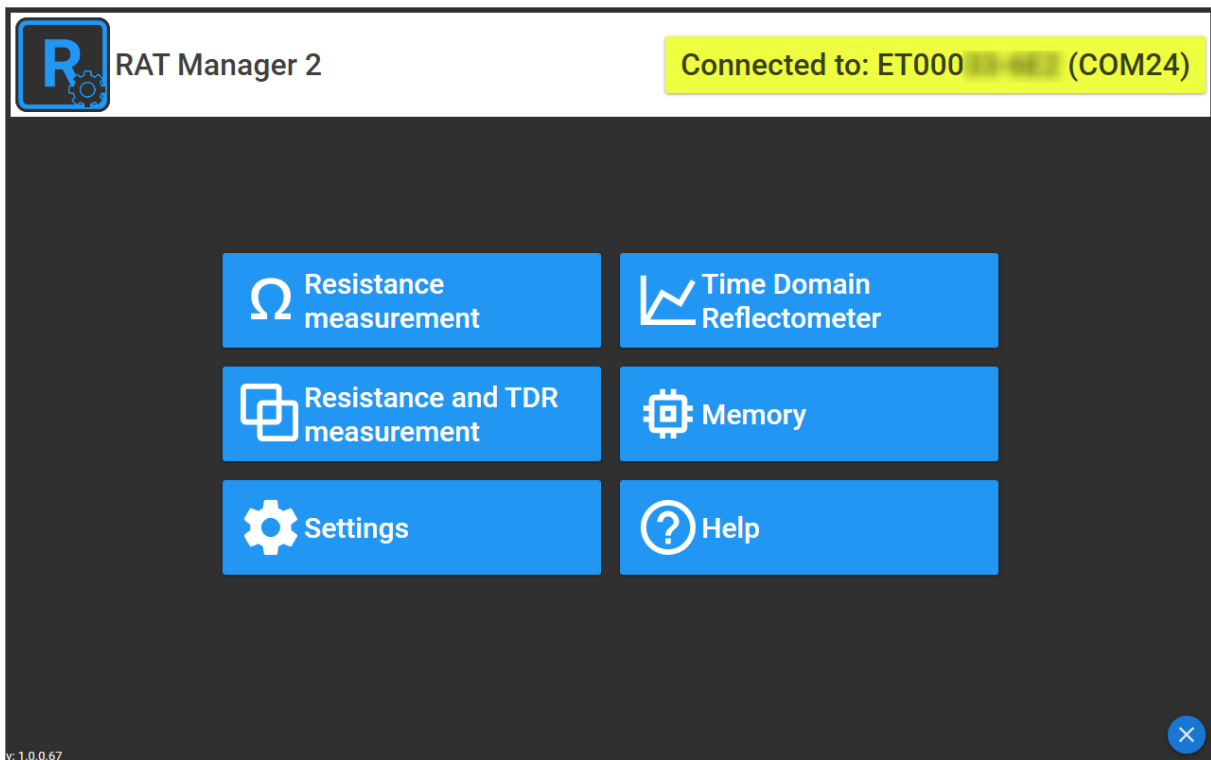

5. Select the [Settings] => [Meter configuration]. The application should automatically load the default settings. If this does not happen, click [Load from meter].

6. For proper operation of the device with the RATMON system you need to set below parameters:

(1) APN address - individual for each GSM operator.

(2) SIM card PIN - enter the correct SIM card PIN. If the SIM card is not blocked, enter "0000".

(3) Server settings - enter the server address to which all results are to be sent. The default is app.ratmon.com

(4) Setting of first measurement, frequency of test and energy saving mode

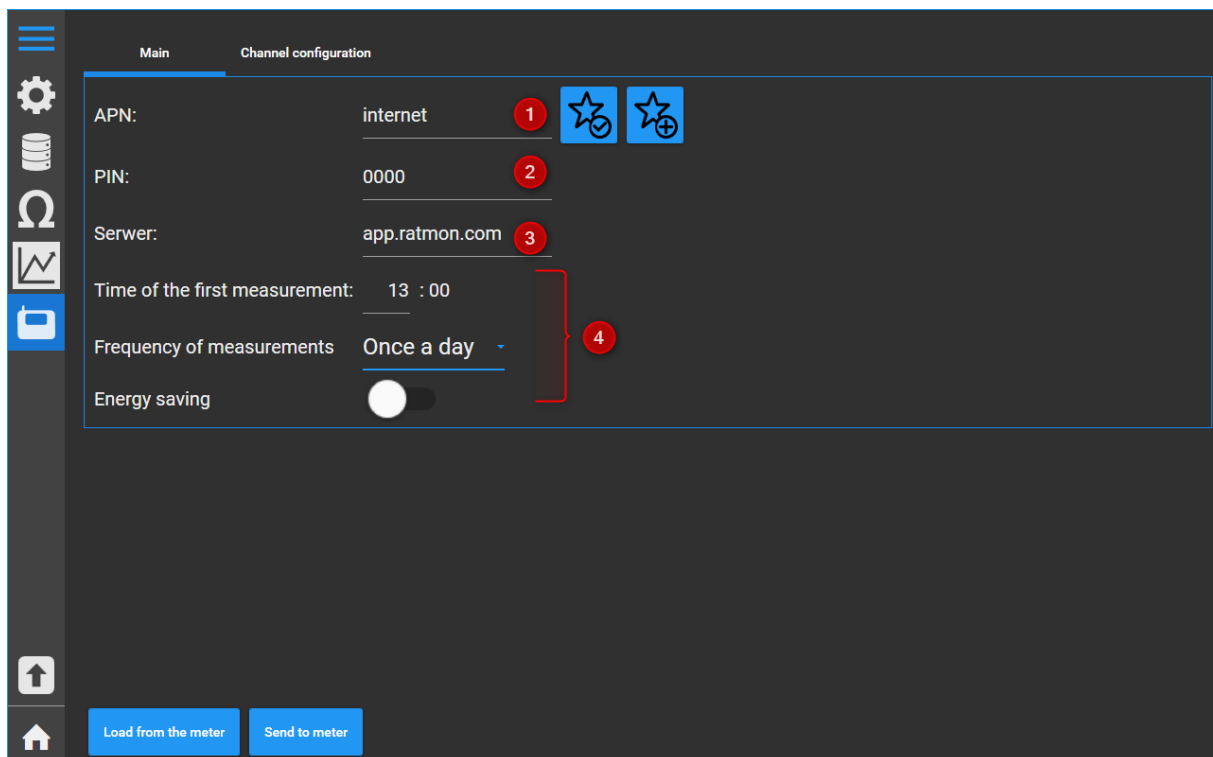

7. After entering the configuration, click [Save to meter].

8. The device is ready to work with the RATMON system.

RATMON SYSTEM

In order to view the results and manage the device, log in to the RATMON system at:

www.app.ratmon.com

The first step is to add the device to RATMON system and assign it to pipe loop. A detailed description is available in the "Help" of the RATMON system in Chapter 1 "First steps".

FRONT PANEL

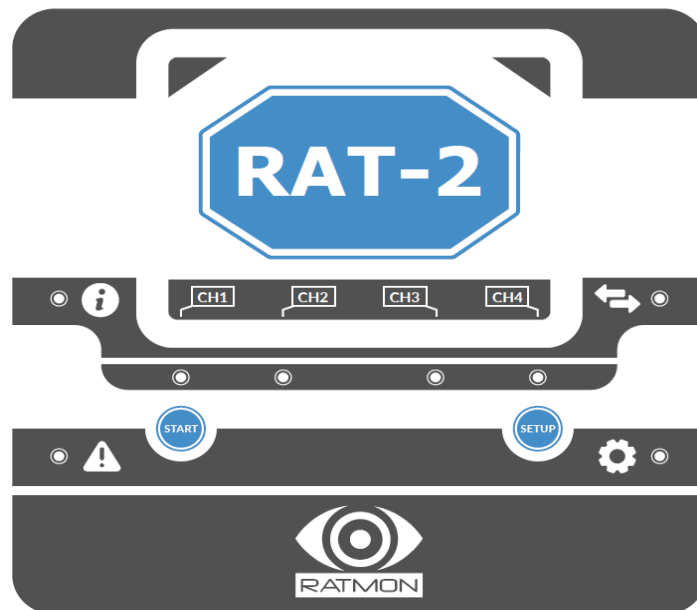

Colours of LEDs

-  - dark blue
-  - light blue
-  - green
-  - red
-  - orange
-  - purple
-  - white

LEDs and buttons on front panel



Status



Alarm



Communication



Functions

CH1 channel 1

CH2 channel 2

CH3 channel 3





CH4 channel 4

„Setup” Button to select function





„Start” Button to start selected function

DESCRIPTION / FUNCTIONS OF LEDS







Status LED

-  constant light - normal work of device
-  constant light - work with PC (via USB), operating by RATManager2
-  3x flashing - device going into sleep mode (energy saving mode)
-  constant flashing – searching for wireless communication (option)
-  constant light – connected via wireless communication with PC and RATManager 2



Dioda Alarm



-  Blink, device not configured in the system
-  Constant, loop control alarm, broken alarm loop
-  Constant, no failure, assessment based on reflectometric measurement (sensor cable)
-  Constant, failure on one of the channels, evaluation made on the basis of reflectometric measurement (sensor cable)

Communication LED







-  3x flashing - too weak signal strength to communicate via GSM
-  constant flashing - searching for GSM connection
-  3 x flashing - successful connection with server (RATMON)
-  slow flashing - lack of SIM card or problem with SIM card
-  fast flashing - problem with connection with server/RATMON. Next attempt to connect will be done by next measurement.
-  constant flashing - problem GSM communication, device continues attempts to connect with GSM network
-  constant light - firmware update

Setup LED

-  triggering of resistance measurement
-  triggering of TDR measurement (RATCombo)

-  checking of GSM signal strength
-  starting of wireless communication (optional)
-  Select the device in pipe disconnection mode

LEDs CH1..CH4

-  warning - exceeding the warning threshold on channel CH X
-  alarm - exceeding the alarm threshold on channel CH X
-  resistance measurement on CH X
-  TDR measurement on channel CH X
-  flashing – firmware update in progress
-  level of GSM signal strength







LED OPERATION AFTER STARTING THE DEVICE

1. Operating modes of the device.

After starting the device, Status LED  lights up blue. After connecting the device with PC (USB) colour changes to green.

2. GSM communication.

After switching on the device starts automatically connection with GSM network, by following steps:

- Communication LED  is flashing blue.
- After connection to GSM network, device shows GSM signal strength on LEDs „CH1” to „CH4” by lighting purple.
- Next device starts to communicate server:
 - ✓ After successful communication with server, communication LED  flashes green 3x
 - ✓ Device not configured on server, alarm LED  flashes green 3x
- In case SIM card is missing or it is a problem with SIM card communication LED  blinks slowly in red.
- If device has problem to connect with GSM network, communication LED  flashes purple. Device will periodically try to connect again.
- If device failed to connect with the server communication LED  flashes fast in red. The connection attempt will be repeated at the next measurement period.

3. Manual checking of GSM signal strength

In order to check current GSM signal strength, press once button „Setup” until  LED starts flashing purple and next press button „Start”.

The level of GSM signal strength will be presented on LEDs CH1 to CH4 in purple.

4. Manual triggering of resistance measurement

Press button „Setup” until LED  flashes in dark blue. Next press button „Start”. LEDs CH1 to CH4 will inform which channels are ready for measurements. Following pressing of button “Start” triggers measurement. If result is positive, LED CH X stops lighting. If result exceeds set warning or alarm limit, LED of CH X will light yellow or red, respectively.

5. Manual triggering of TDR measurement (RATCombo)

Press button „Setup” until LED  flashes light blue. Next press button „Start” . LEDs of CH 1 to CH 2 will inform which channel is ready for measurements. By pressing button „Setup” you can change channel. Following pressing of button „Start” triggers measurement.

6. Remote update of the device

When the update process starts communication LED  light in white and update progress is presented on LEDs CH1 to CH2 in green.

DISPOSAL

Used electrical and electronic equipment should be collected selectively, i.e. it must not be placed with other types of waste.

Worn-out electronic equipment should be taken to a collection point in accordance with the Waste Electrical and Electronic Equipment Act.

Before handing over the equipment to a collection point, do not disassemble any parts from this equipment yourself.

Observe local regulations regarding disposal of packaging, waste batteries and accumulators.